

Smart4418

Revision

1512 , First Version



Smart4418		
Size	Document Number	Rev
A3	01.Title	1512
Date:	Monday, March 07, 2016	Sheet 1 of 12

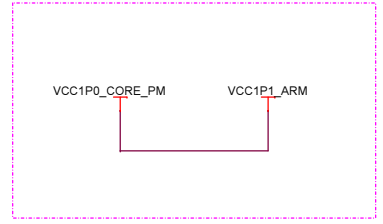
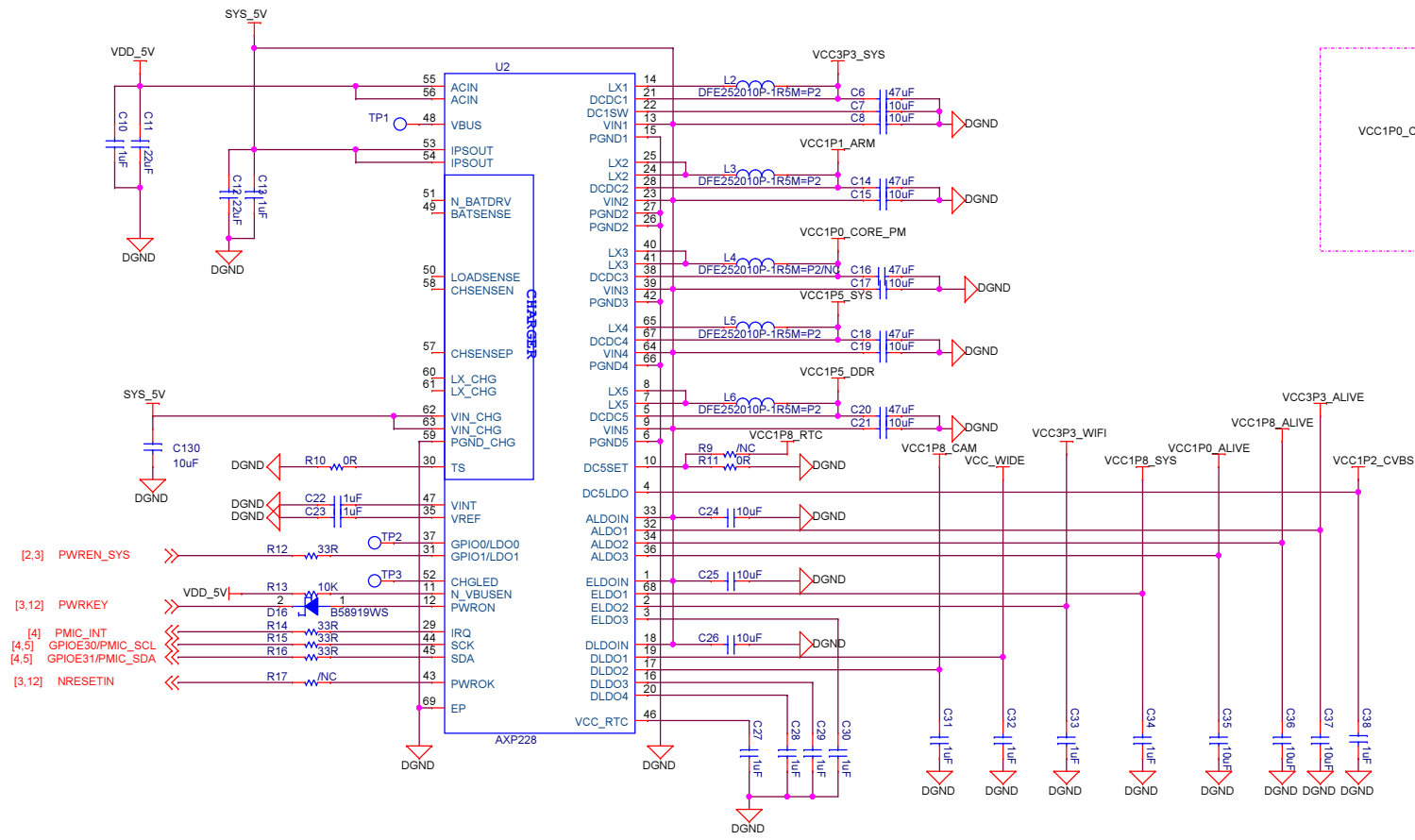

VCC1P0_CORE_DC:1.1V

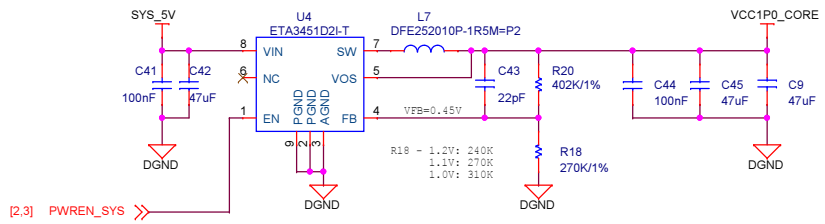

RTC Power

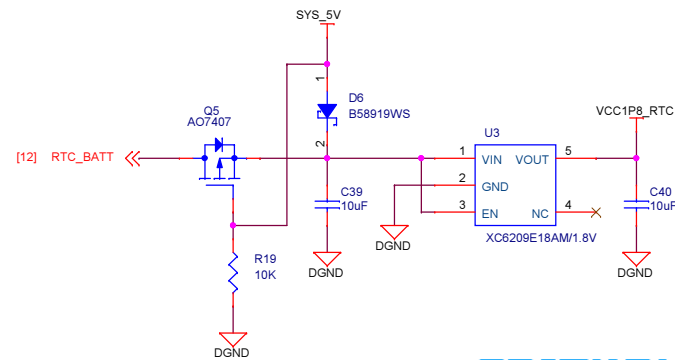

Smart4418		
Size A3	Document Number 02.PMIC	Rev 1512
Date: Monday, March 07, 2016	Sheet 2	of 12

System Reset, Clocks

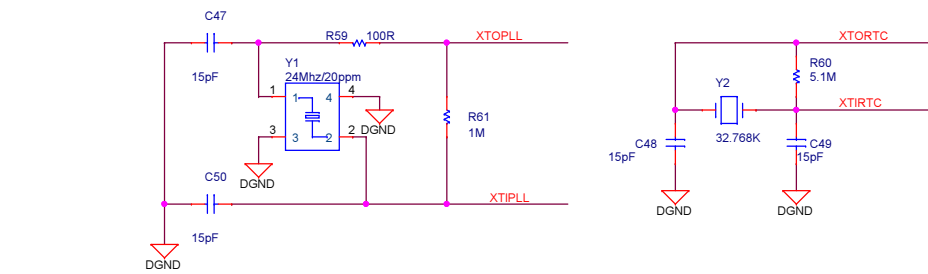
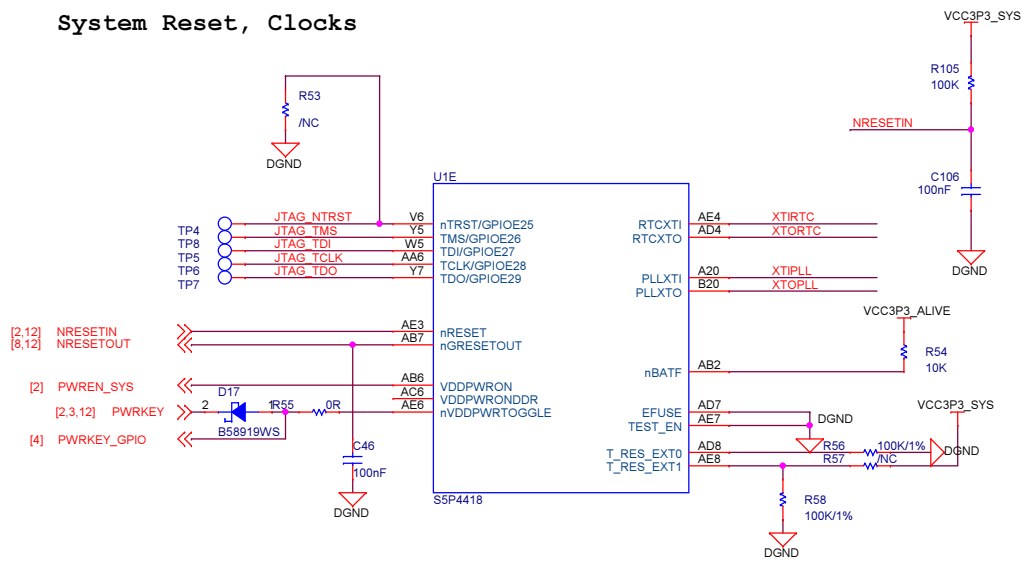

Boot Mode Config

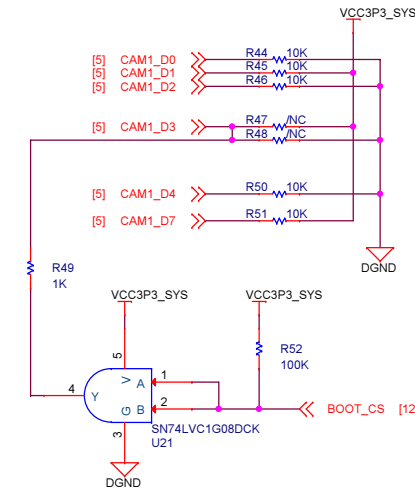
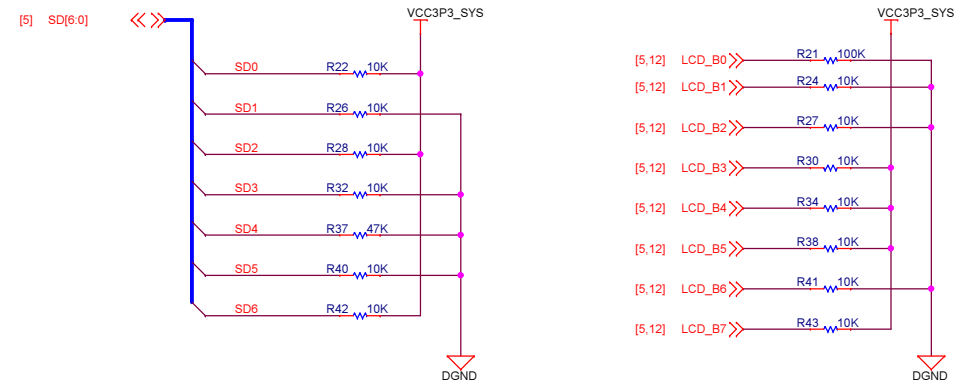

BOOT MODE OPTION

	eMMC	SPI	USB	NAND
SD0	HIGH	LOW	LOW	HIGH
SD1	LOW	LOW	HIGH	HIGH
SD2	HIGH	HIGH	HIGH	HIGH
SD4	LOW	HIGH		
SD5	LOW	LOW		

Boot media port select (SPI, eMMC)

	CH0	CH1	CH2
SD3	LOW	HIGH	LOW
CAM1_D3	LOW	LOW	HIGH

Sleep Detect

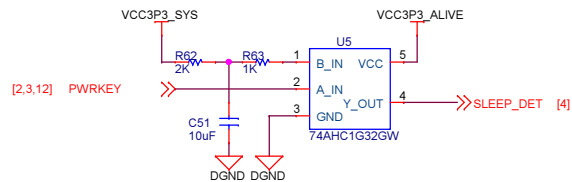

PCB Version

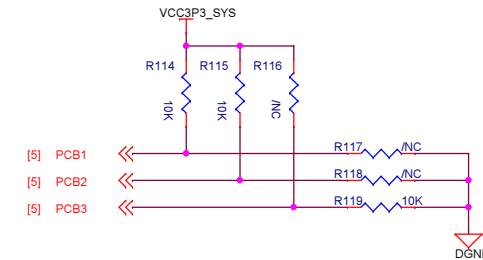

FRIENDLYARM

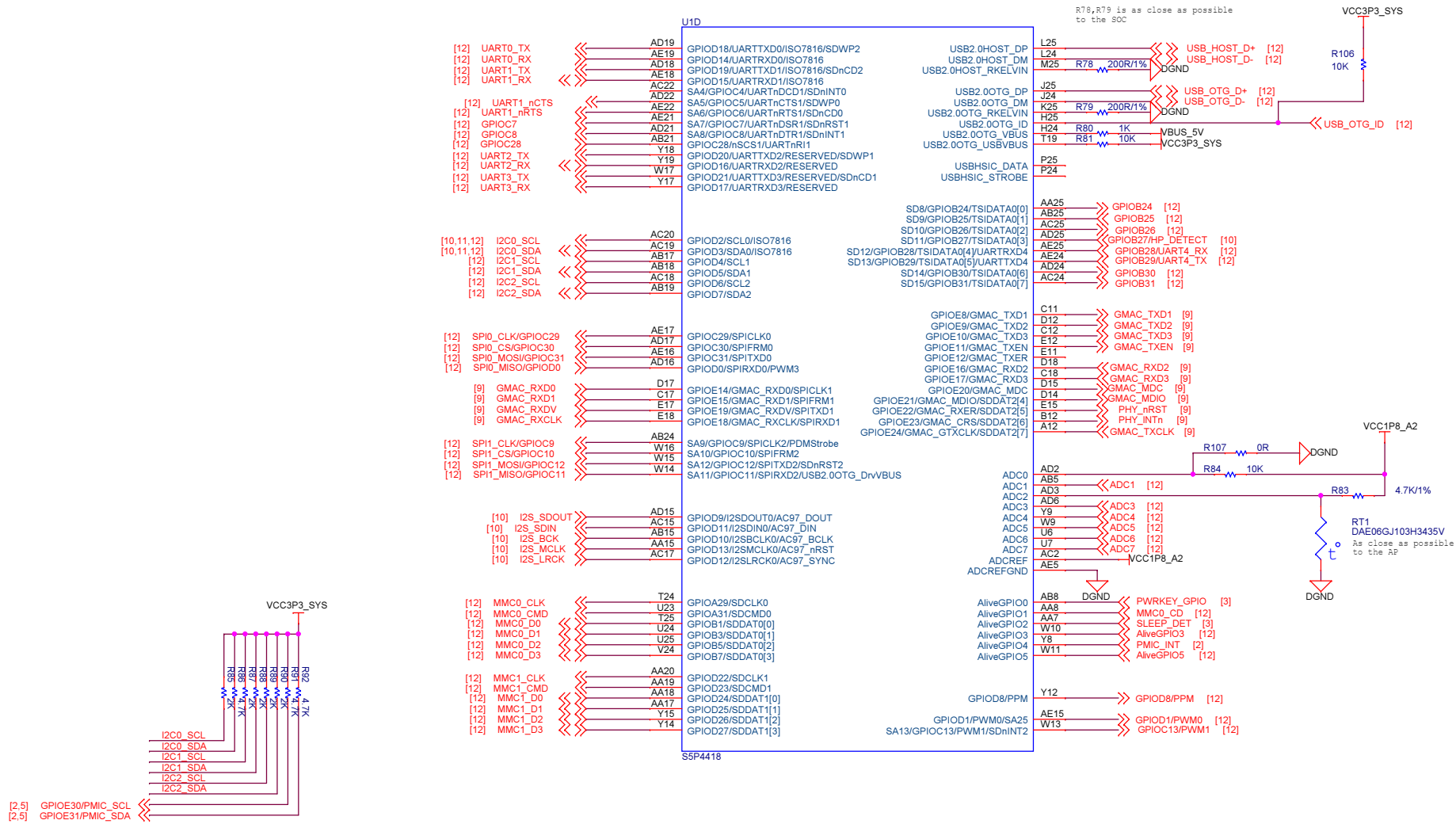

Reserved Function

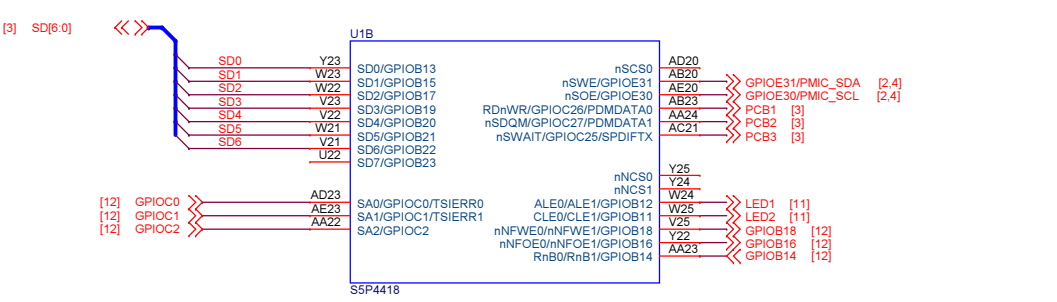
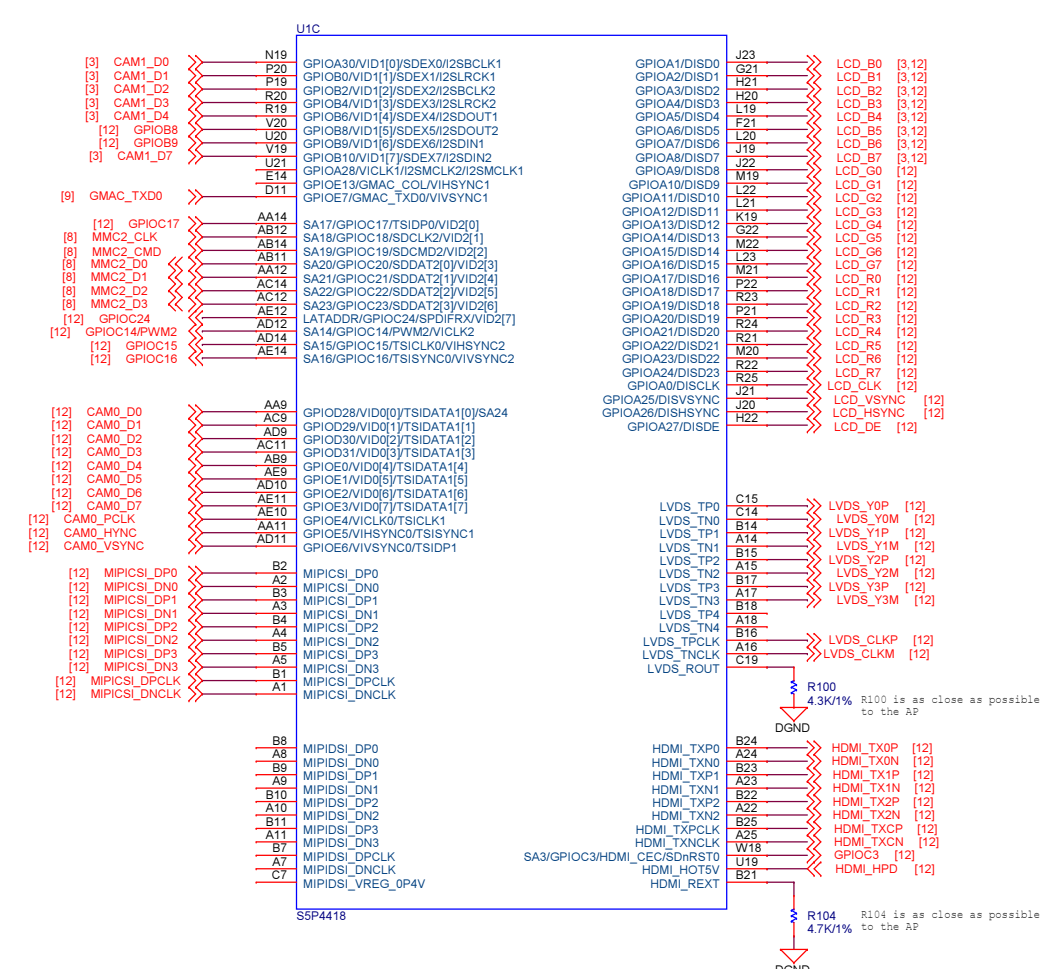
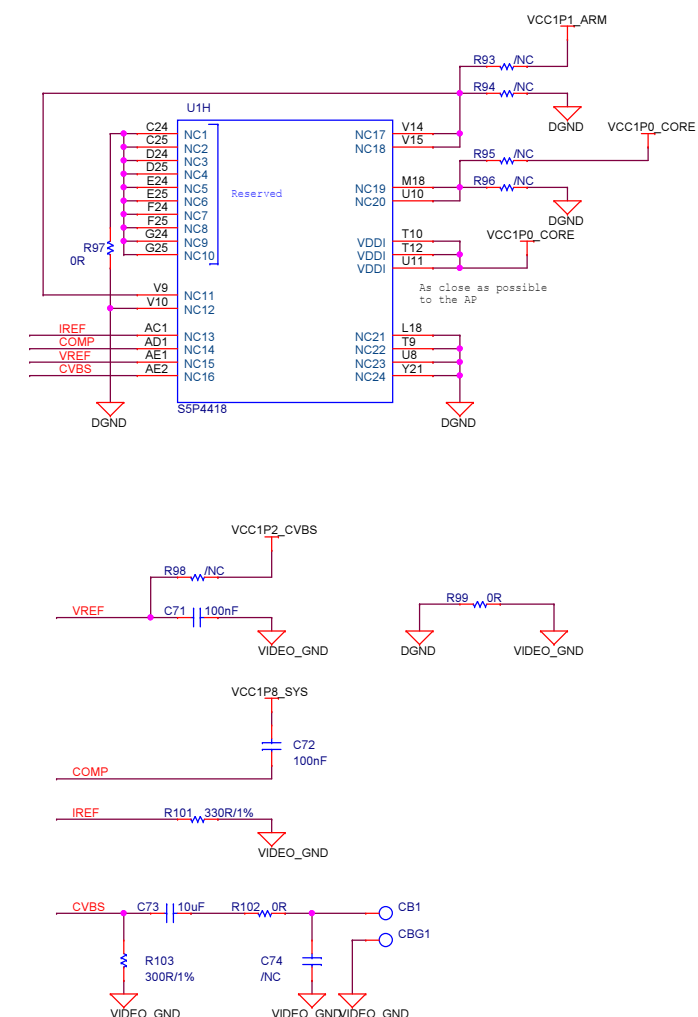

Smart4418		
Size A3	Document Number 05.AP VIP&Display	Rev 1512
Date: Monday, March 07, 2016	Sheet 5	of 12

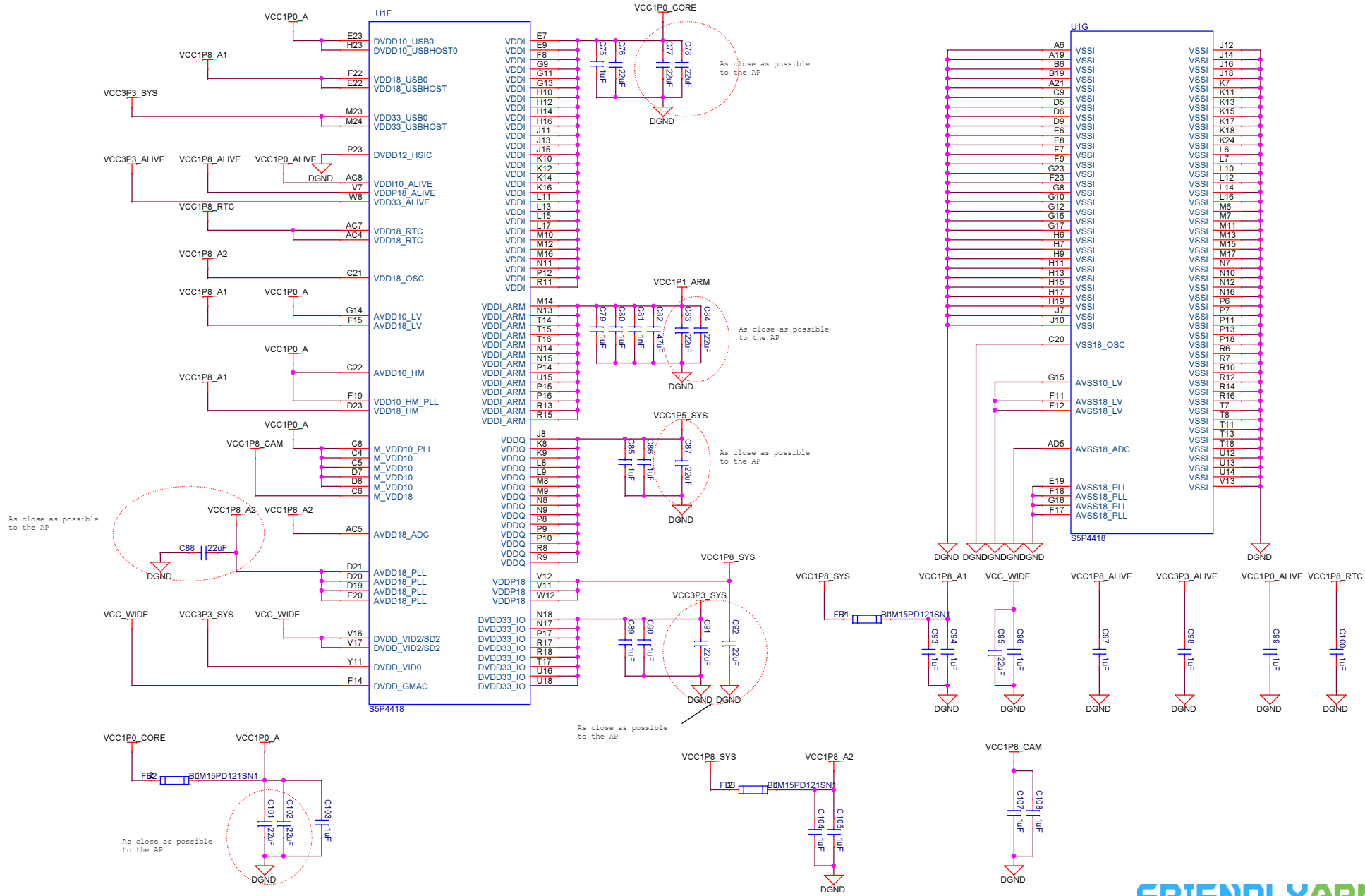

Smart4418		
Size A3	Document Number 06.AP Power	Rev 1512
Date: Monday, March 07, 2016	Sheet 6 of 12	

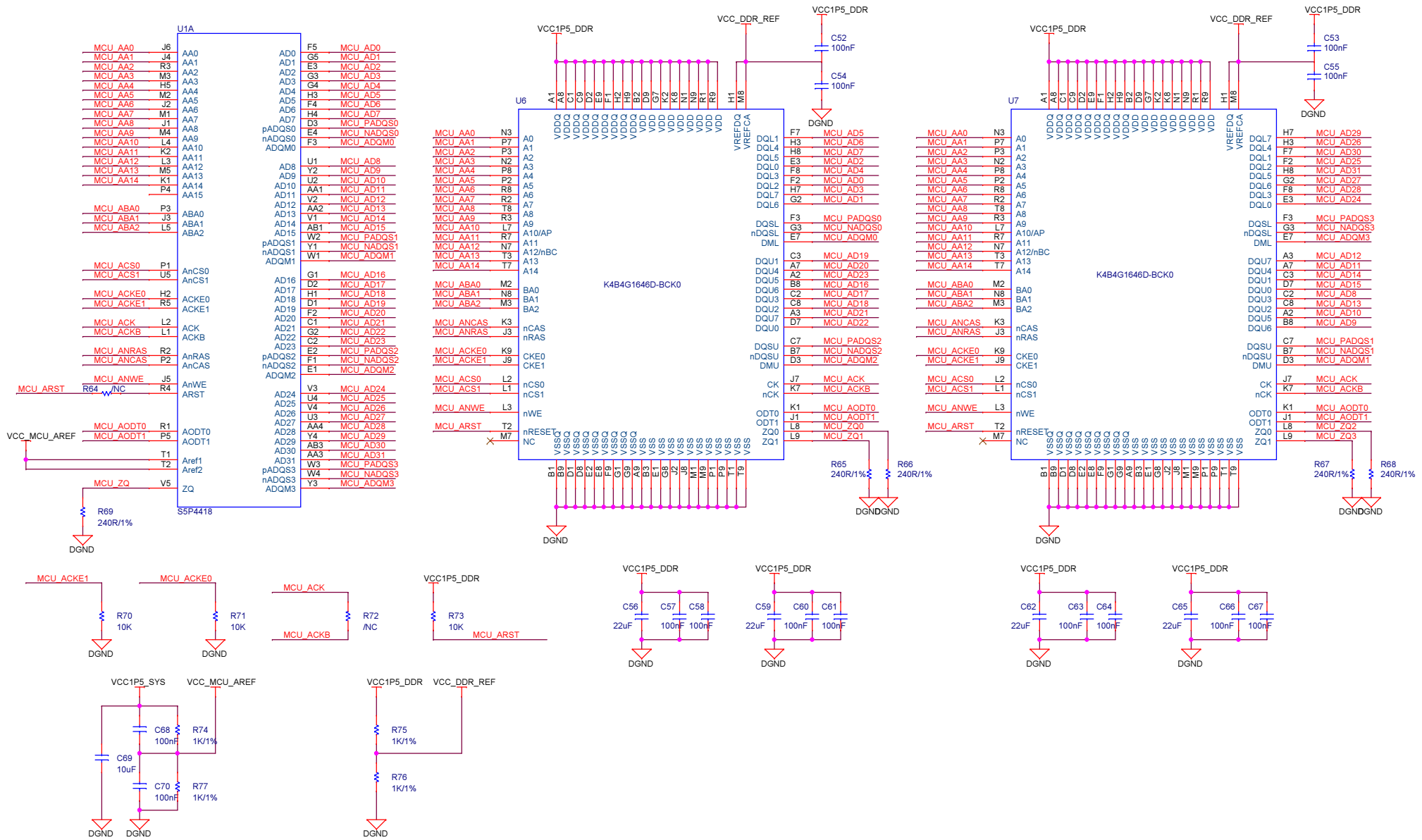

Smart4418		
Size	Document Number	Rev
A3	07_DDR III	1512
Date:	Monday, March 07, 2016	Sheet 7 of 12

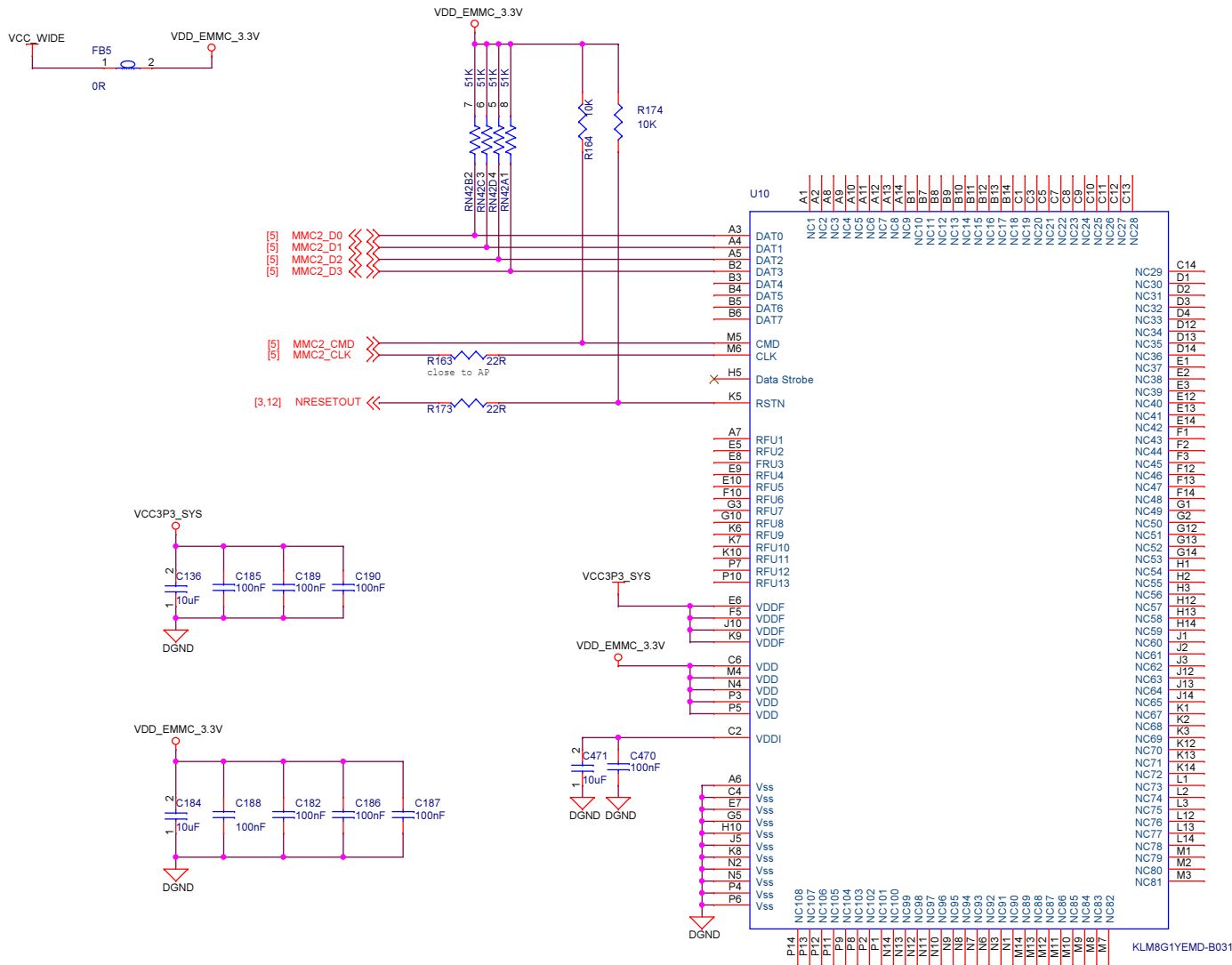

10/100/1000M Ethernet

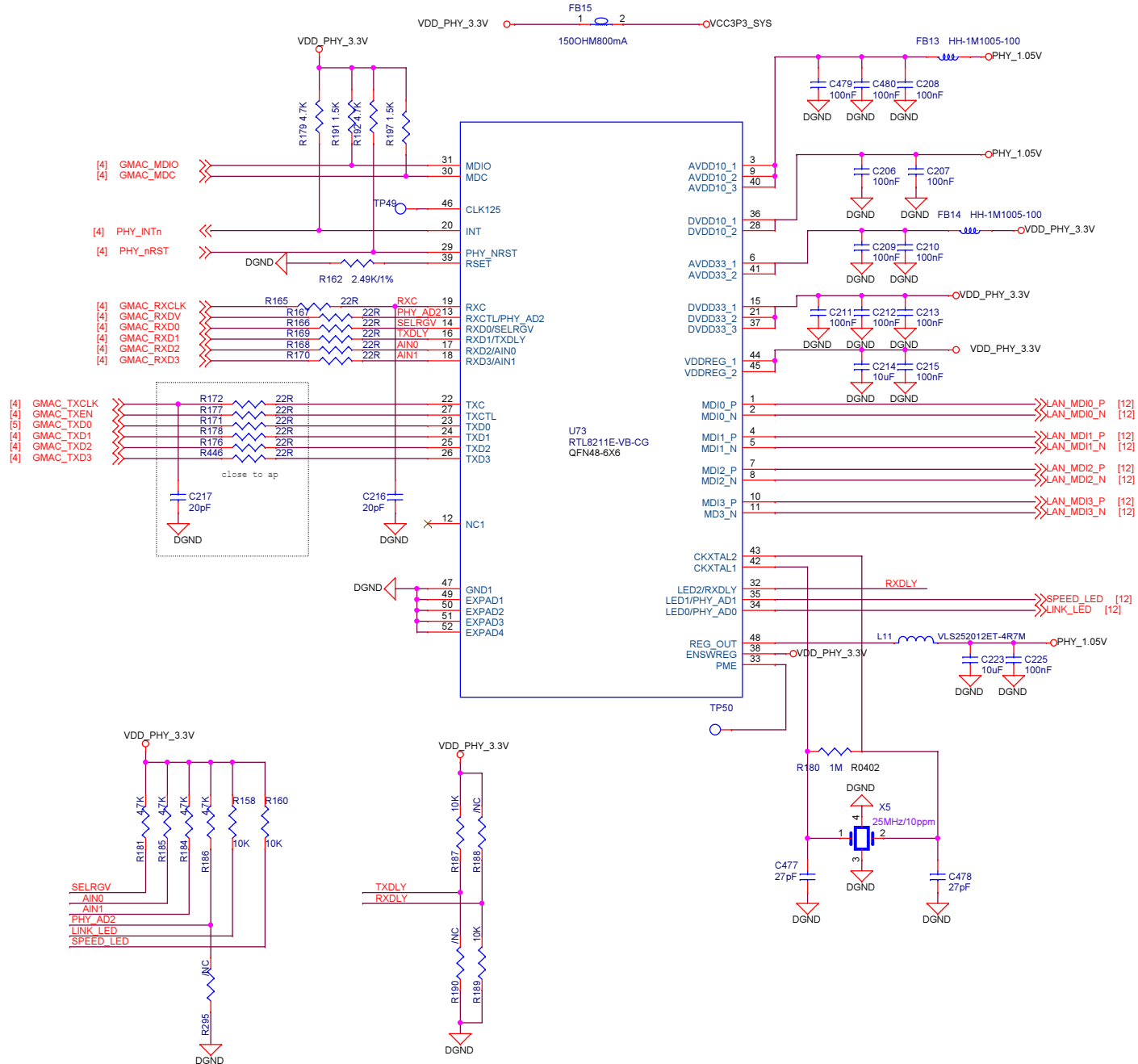

Smart4418		
Size A3	Document Number 09.LAN.PHY	Rev 1512
Date: Monday, March 07, 2016	Sheet 9	of 12

Audio

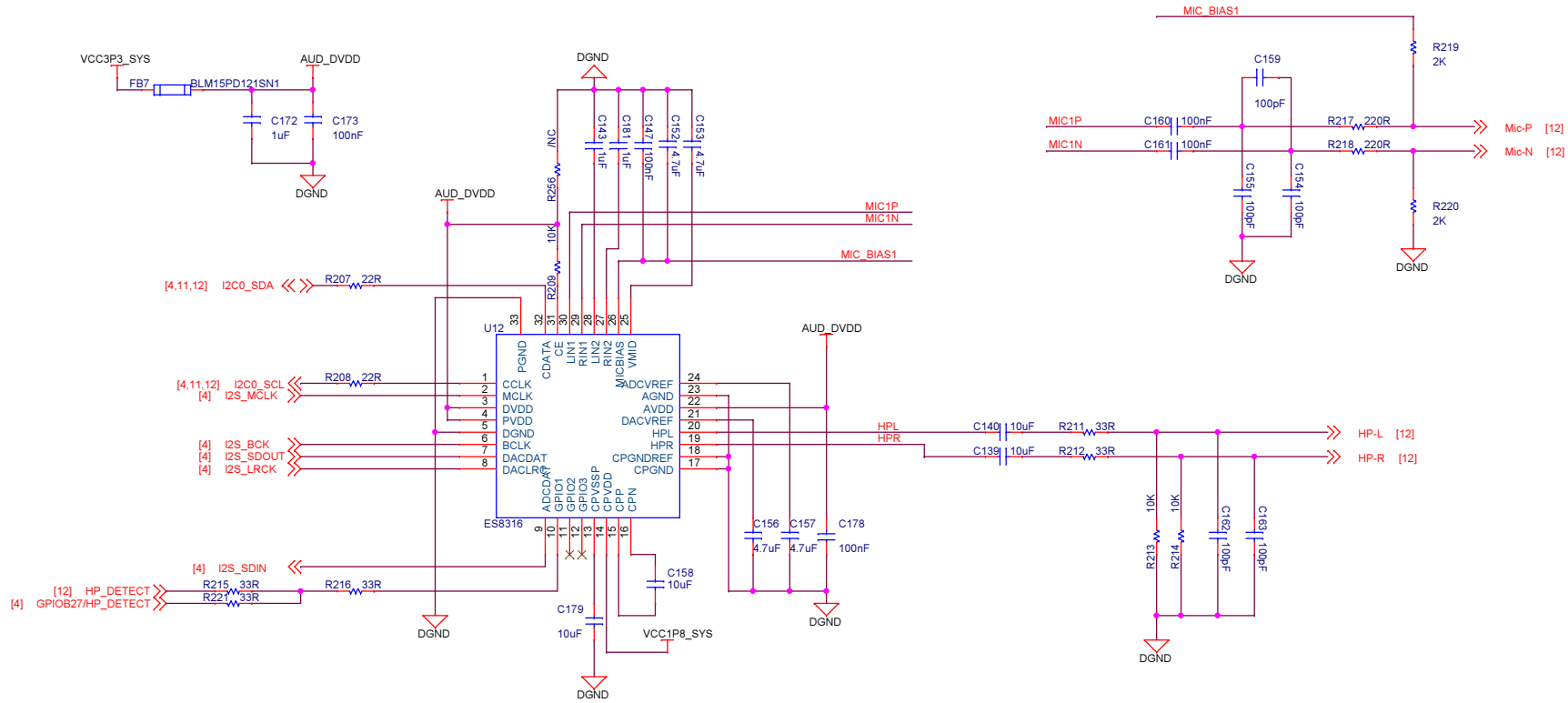

FRIENDLYARM

Smart4418		
Size A3	Document Number 10.Audio	Rev 1512
Date: Monday, March 07, 2016	Sheet 10	of 12

CryptoAuthentication

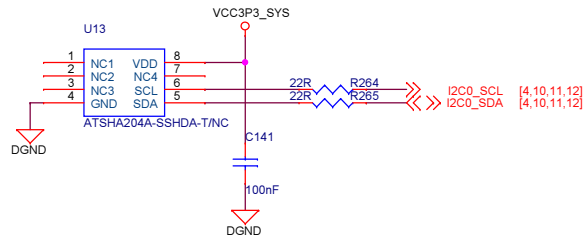

EEPROM with MAC Address

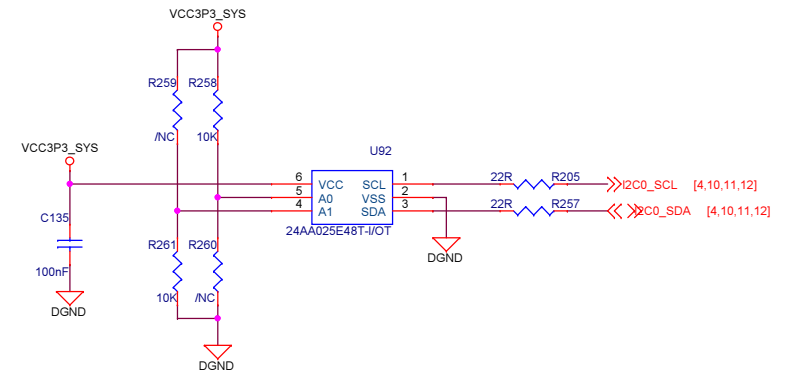

LEDs

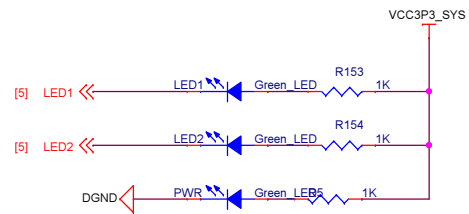

FRIENDLYARM

Smart4418		
Size A3	Document Number 11.EEPROM, SHA-256	Rev 1512
Date:	Monday, March 07, 2016	Sheet 11 of 12

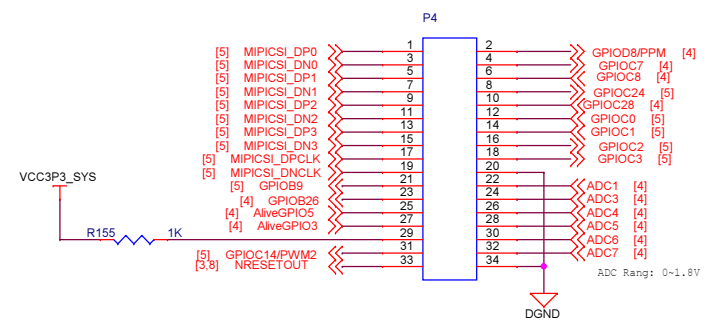
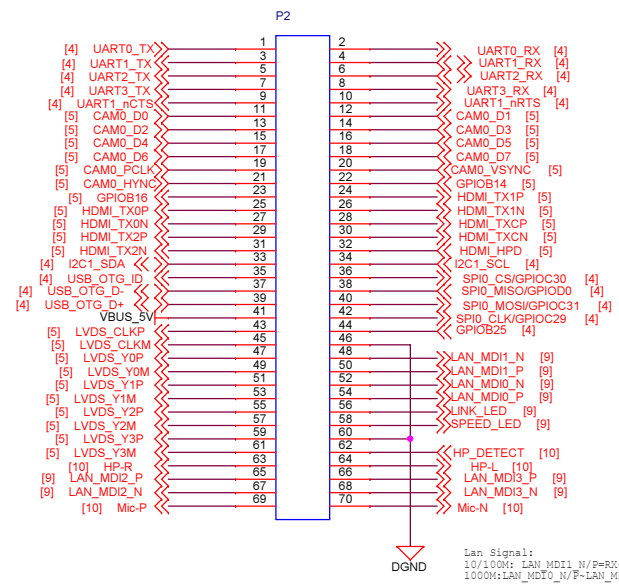
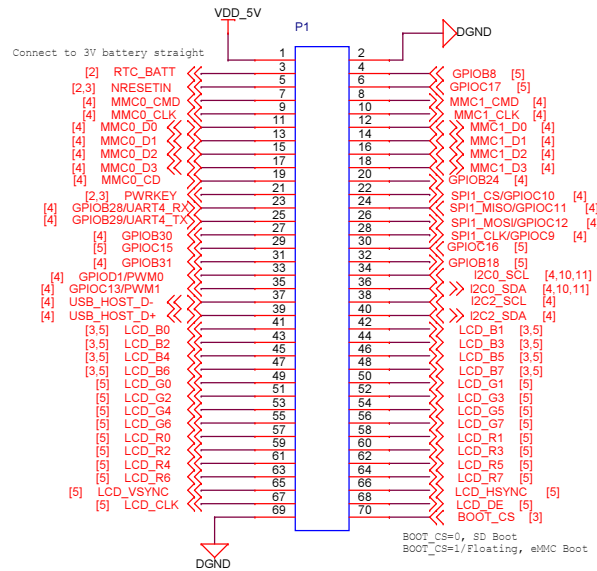

Smart4418		
Size A3	Document Number 12.Connector	Rev 1512
Date: Monday, March 07, 2016	Sheet 12	of 12